

## **Features**

### **Measurements**

- All 3-phase AC measurements
- True RMS
- Replaces analogue meters
- Demand on each phase current

### **Accuracy**

- U, I and F class 0.5
- Other values class 1.0

### **Installation**

- Compact dimensions
- Simple wiring

### **Display**

- 4 display rows
- 58 x 66mm
- White backlight

### **Intelligent**

- Suitable for all 3-phase network topologies
- Replaces transducers

### **Models**

- MIB 7000: Basic
- MIB 7000C: Basic + RS485 Modbus communication
- MIB 7020: Basic + 2 digital outputs

**Application**

The MIB multi-instrument is a microprocessor-based measuring unit providing measurement of most electrical quantities on a 3-phase electric energy distribution network. The measurements are shown on the built-in display.

The product family includes three versions:

- MIB 7000 (basic)
- MIB 7000C (basic + RS485 Modbus communication)
- MIB 7020 (basic + 2 digital outputs)

True RMS values on all 3-phase network topologies are measured with/without neutral and with both balanced and unbalanced load.

A large number of standard analogue instruments can be replaced by the MIB in all electrical measuring applications. The MIB contains all necessary measuring circuits and presents all values on a display with white backlight. The display has 4 digits resolution for all measurements. The backlight on-time is selectable.

Operating the MIB is very easy. It is a flexible and logical measuring unit that enables the user to easily adapt the instrument to the individual application. Counter reset and change of settings can be password protected.

**Measured and calculated values**

Voltage

True RMS – each phase and line-to-line voltage.

Current

Each phase, average and neutral.

Active power (P)

Active, total and demand – power.

Reactive power (Q)

Reactive, total and demand reactive – power.

Apparent power (S)

Apparent and total apparent power.

Power factor

Power factor and total power factor.

Frequency

Actual frequency of L1.

Load nature

L/C/R.

Digital output (DO)

For alarm output or energy pulse output.

Min./max.

Min./max. of voltage – max. of current and demand.

Energy pulse output

Two ports of pulse output (assign to any energy and reactive energy).

THD (up to 15th harmonics)

Voltage THD of each phase and total, current THD of each phase and total.

Demand

Demand of each phase current, power and reactive power.

Energy

Import and export of energy, inductive and capacitive of reactive energy.

Alarm

Alarm can be related to any metering parameters.

Running hour

Meters the duration of the operation.

Unbalance factor

Voltage and current.

**Connection**

The MIB can be used in almost all 3-phase network topologies with/without neutral and with both balanced and unbalanced load. The voltage and current input wiring modes are set separately in the parameter setting process. The voltage wiring mode can be:

- 3LN 3-phase 4-line Y
- 2LN 3-phase 4-line Y with 2 VT
- 1LN 1-phase 2-line
- 2LL 3-phase 3-line open delta
- 3LL 3-phase 3-line direct connection

The current input wiring mode can be:

- 3CT Unbalance system
- 2CT Unbalance system without N
- 1CT Balance system

Any voltage mode can be grouped with any of the current modes. The MIB is supplied configured in 3-phase 4-wire unbalanced mode, i.e. voltage wiring mode 3LN and current input mode 3CT (3W4).

**Communication (optional)**

- Suitable for SCADA systems
- RS485 serial output
- Modbus RTU protocol

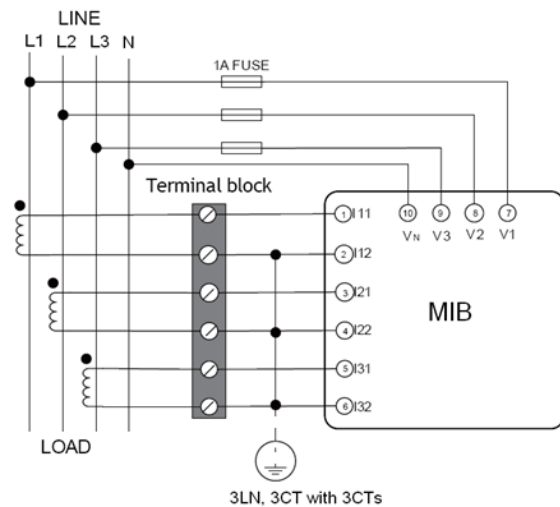

Digital output

MIB 7020

MIB 7020 has two digital outputs that can be used either as pulse outputs for active/reactive energy or as over/under limit alarm signals. The digital outputs are suitable for driving tariff devices or AC/DC relays.

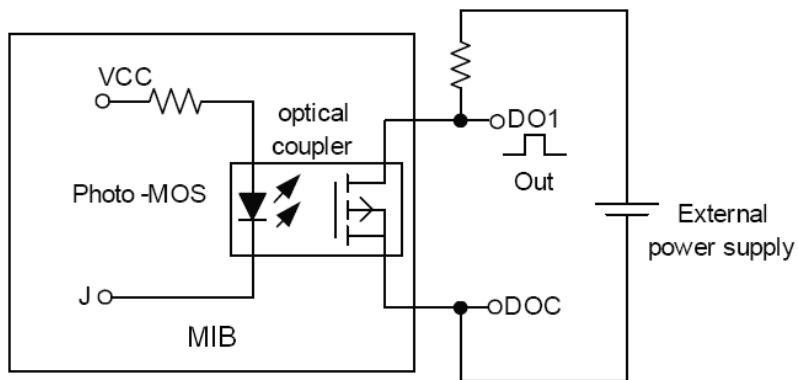

Digital output circuit (pulse)

## Technical specifications

**Voltage inputs**

Nominal voltage $U_N$	L-N 400V AC L-L 690V AC
Measuring range	0 to 1.2 x $U_N$
Overload capacity	2 x $U_N$ continuously 2500V for 1s
VT primary	50V...1000kV
VT secondary	50V...400V
Fuse	1A/230V

**Current inputs**

Nominal current $I_N$	1 or 5A AC
Measuring range	0 to 1.2 x $I_N$
Overload capacity	10A continuously 100A for 1s
CT primary	5A...50kA

**Frequency**

Nominal frequency $f_N$	50/60Hz
Measuring range	45Hz to 65Hz
Measuring point	V1 phase voltage

**Accuracy**

Voltage	0.5% of range
Current	0.5% of range
Power	1.0% of reading
Power factor	1.0% of range
Frequency	0.5% of range
Energy	1.0% of range
Harmonic	2.0% of range

**Auxiliary power supply**

Universal AC/DC power supply	
Supply voltage AC:	100...415V AC +/-10% 50/60Hz/100...300V DC
Consumption	$\leq 2VA$
Fuse	1A/250V AC
Power consumption	3VA@230V AC

**Digital output (optional)**

Output form	Digital output NE (normally energised) NC (normally closed) circuit form is Photo-MOS
Optical isolation	4kV AC rms
Voltage max.	250V AC/300V DC
Current max.	50mA
Pulse rate	0.1...600kWh/pulse 0.1...600kVAh/pulse
Pulse duration	20ms...1s

**Communication (optional)**

Signal levels	RS485
Connection type	Multi-drop
Devices per link	Max. 32 units
Cable type	Belden 3105A or equivalent (twisted pair)
Maximum cable length	up to 1000m
Transmission mode	Asynchronous
Message format	Modbus RTU
Data rate	1 200 to 38 400 bits/s

**Environmental conditions**

Working temperature, display	-10...55°C
Storage temperature	-40...85°C
Humidity, relative	0-95% non-condensing
Temperature drifts Standard	<100ppm/°C EN 60068-2/-1,-2

**Connections**

Measuring inputs	Firm terminal block
Wire max.	5mm <sup>2</sup> /AWG10
Screw torque	0.5Nm/5.5 lb-inch
Other	Pluggable block
Wire max.	1.5mm <sup>2</sup> /AWG16
Screw torque	0.25Nm/2.5 lb-inch

**Mounting**

Panel mounted	Max. 6mm thick
Panel cutout	92 x 92mm +0.8mm (3.62" x 3.62") or 4" round

**Protection**

Front	IP52 (EN 60529)
Rear	IP30 (EN 60529)

**Weight**

350g (0.8 lbs.)

**Material**

Environmental	IEC 60068-2
---------------	-------------

**EMC**

EN 61000-6-1/2/3/4

**Safety**EN 61010-1/UL  
61010-1  
Cat. III, pollution degree 2**Test voltage**2.2kV according to  
EN 61010-1

Unit dimensions in mm (inches)

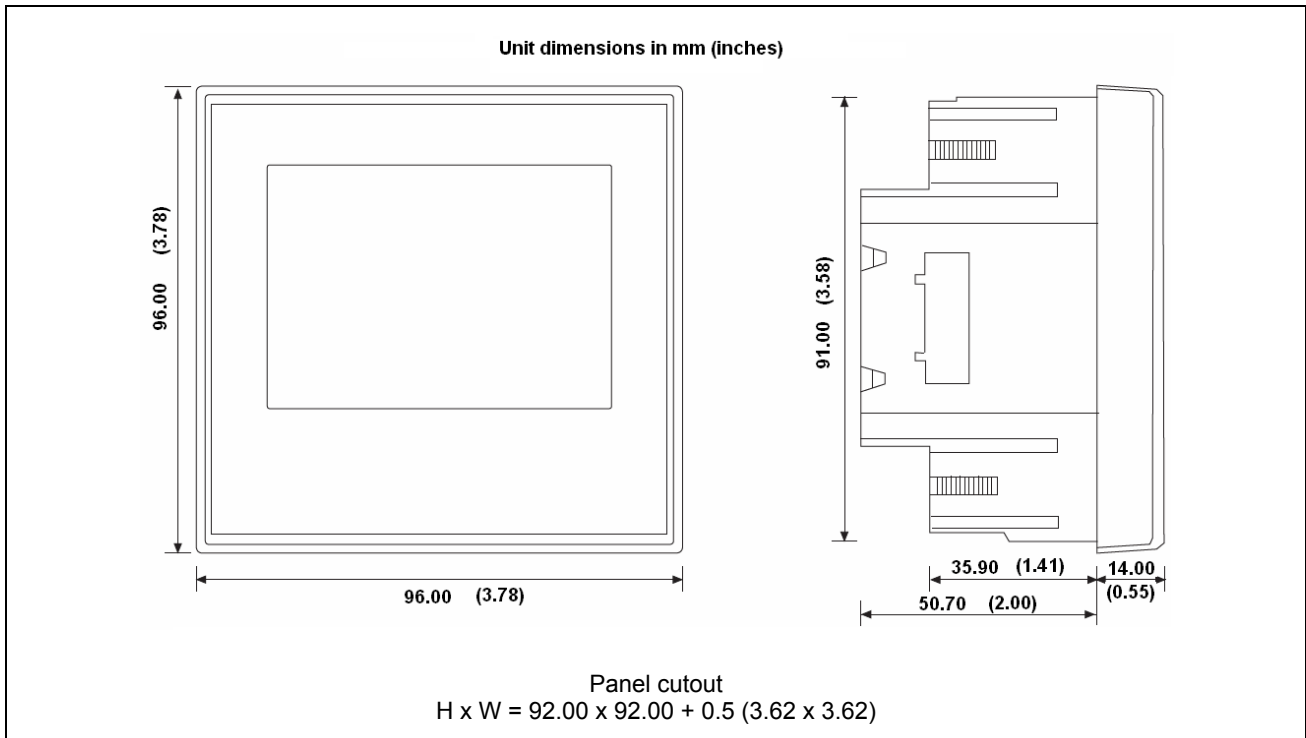

Available accessories

Type	Description	Item no.
Accessory for MIB	Bracket for DIN rail mounting	2232700011

Order specifications

<b><u>MIB 7000</u></b>	<b><u>MIB 7000C</u></b>	<b><u>MIB 7020</u></b>
<b>690V AC (L-L) 5A No digital output</b>	<b>690V AC (L-L) 5A No digital output RS485 Modbus communication</b>	<b>690V AC (L-L) 5A 2 digital outputs</b>
<b>Aux. supply: 100...415V AC 100...300V DC</b>	<b>Aux. supply: 100...415V AC 100...300V DC</b>	<b>Aux. supply: 100...415V AC 100...300V DC</b>
DEIF no. 1211020007 EAN no. 5703727106882	DEIF no. 1211020011 EAN no. 5703727108564	DEIF no. 1211020008 EAN no. 5703727106899

Due to our continuous development we reserve the right to supply equipment which may vary from the described.



DEIF A/S, Frisenborgvej 33  
DK-7800 Skive, Denmark



Tel.: 9614 9614, Fax: 9614 9615  
E-mail: deif@deif.com, URL: www.deif.com

